

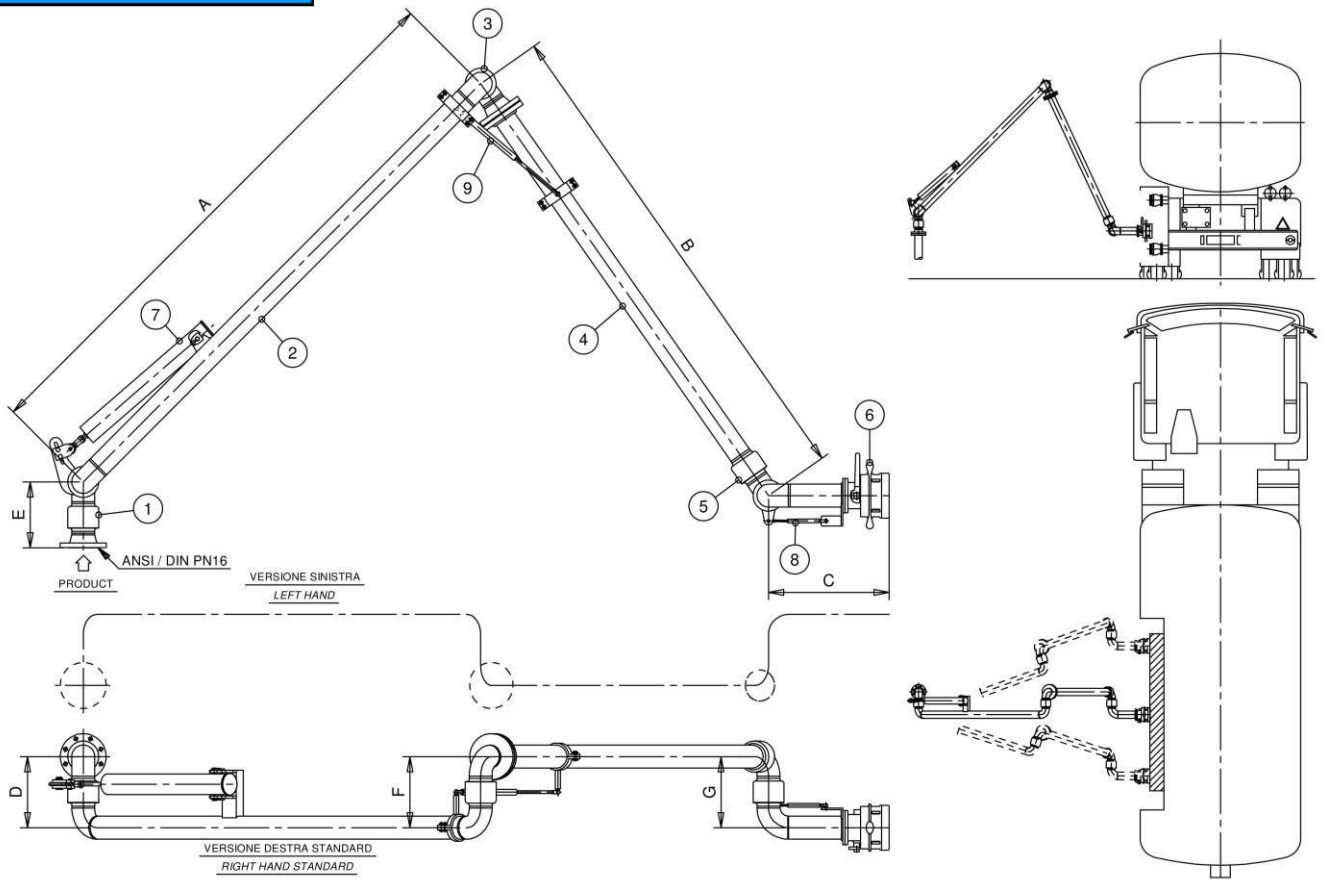

INFILTEK

“A frame” triple range bottom loading arm 2475 Model



Operating Conditions

Design Pressure	10.0 Bar G
Test Pressure	15.0 Bar G
Design Temperature	-15° C / +65°C
Seal Material	VITON PTFE Special VITON (*)
Flow Rate	3"–330 LPM Max 4"–660 LPM Max

N. Description

1	Style 50 double swing joint
2	Inboard pipe
3	Style 40 swivel joint
4	Outboard pipe
5	Style 50 double swing joint
6	Dry-disconnect coupler
7	Spring balancing cylinder
8	Gas spring balancer
9	Gas spring balancer

Dwg/Mod

2174
.
2174
.
2175
OMC C-3659
05182
.
.

Standard Dimensions

Dn.	3"	4"
A	1500/2800	1500/2800
B	1500/2800	1500/2800
C	600	600
D	296	353
E	289	328
F	279	343
G	279	343
Weight	130	160

