

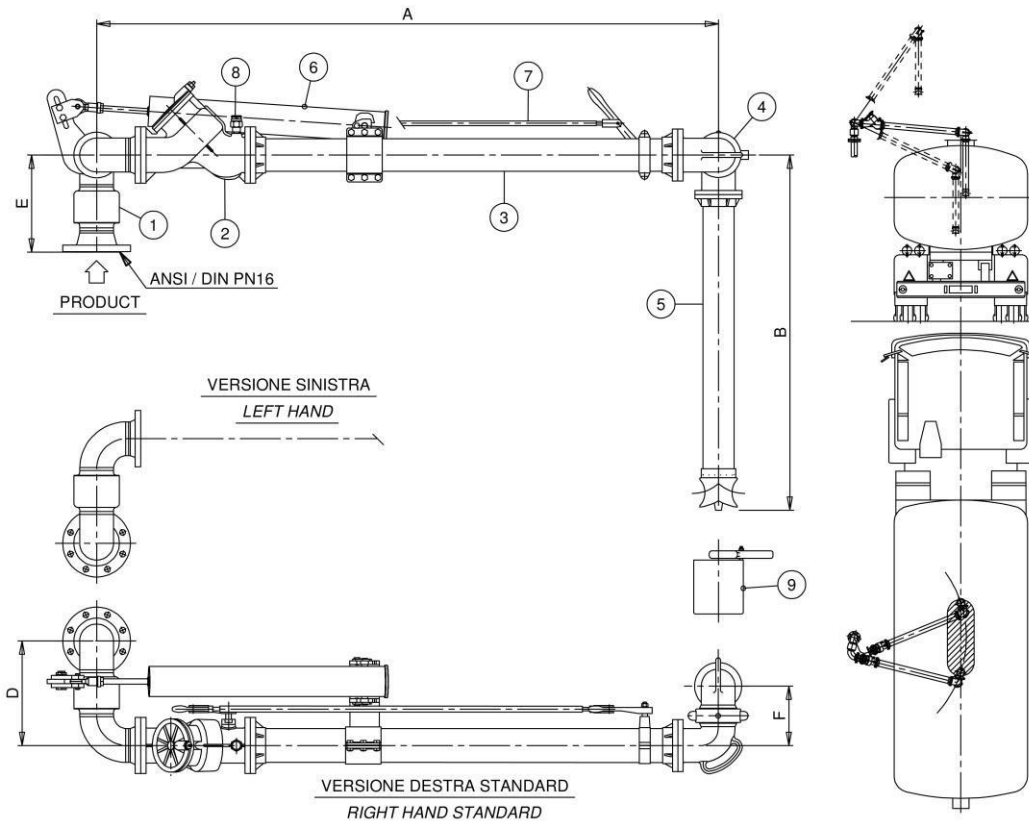

INFILTEK

Fixed range top loading arm 622-BC / 722-BC Model



Operating Conditions

Design Pressure	10.0 Bar G
Test Pressure	15.0 Bar G
Design Temperature	-15° C / +65°C
Seal Material	VITON Nitrile (Buna N) Special VITON (*)
Flow Rate	3"-75 mc/h Max 4"-125 mc/h Max 6"- 280 mc/h Max

N. Description

1	Style 50 double swing joint
2	Loading valve (stay/hold-open)
3	Tube assembly
4	Drop tube swivel
5	Drop tube with "T" deflector
6	Spring balancing cylinder
7	Valve remote control
8	3/8" NPT Vacuum breaker
9	Nipper drip bucket

Dwg/Mod

2174 (*)
2004 (*)
504
.
536
2359-T
05182
2356
2336
2408

Standard Dimensions

Dn.	3"	4"	6"
A	2100	2100	2100
B	1600	1600	1600
C	/	/	/
D	296	353	525
E	289	328	462
F	174	201	278
Weight	85	105	200

Notes

(*) Swivels 2174 Mod. installed on 622-BC Mod. loading arms
Swivels 2004 Mod. installed on 722-BC Mod. loading arms

Options

- Pos.5 with flute beak end (2359-BF)
- Pos.5 with flow deflector (2359-D)
- Microswitch to signal valve opened/closed
- (*) Suitable for BIO-Products

